

AstraDriver

In review

4 Channel LED Driver with PWM dimming input. LED2001PHR is the driver IC, it can support up to 4A, 3V - 18V at 850KHz switching frequency. Tuned for 3.5V at 2.5A and 2.7V at 2.0A.

Features

- JST VH Connectors
- 4x LED2001PHR
- Test plugs for each input & output for easy debugging
- 2.55V 2.1A channel for red
- 3.25V 2.5A channel for blue and converted yellow
- 3.4V 2.5A channel for green

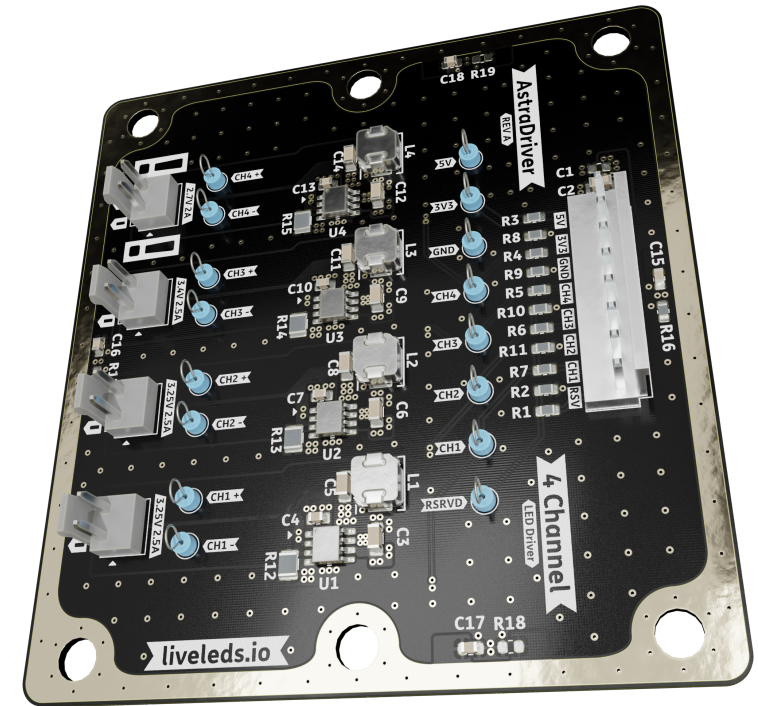

Render for reference only

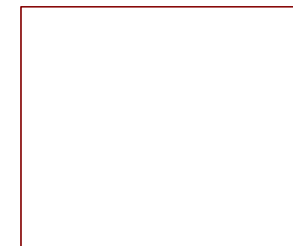

File: overview.kicad_sch



File: block_diagram.kicad_sch

Board Name	Project Name	Company	Sheet Title	Sheet Path & File Name	Date	Revision	Size	Sheet
AstraDriver	AstraBeam	LiveAstra Technologies	AstraDriver - Schematic	/ AstraDriver.kicad_sch	2024-08-26	A	A4	1 of 8

Overview

Page Description

1	Cover
2	Overview
3	Block Diagram
4	Channel 1 Blue and CY
5	Channel 2 Blue and CY
6	Channel 3 Green
7	Channel 4 Red
8	Misc

Notes

- The center of the board will have a 102x30mm heat sink pad.
- Vias will be plugged and capped to avoid issues with exposed pads.
- Test plugs will be hand-soldered on a single test board.
-

QST1

Question

Something is unclear or a missing piece of information potentially needs to be explored further.

INF1

Information

Generic information box to inform about specifics of the part or layout, notes, helpful information.

CRT1

Critical

It is critical to follow the instructions here. Failure to do so will result in poor performance or failure.

WRN1

Caution

Extra care is required here. Pay attention to details, routing, and try your best to follow the advice.

Board Name	Project Name	Company	Sheet Title	Sheet Path & File Name	Date	Revision	Size	Sheet
AstraDriver	AstraBeam	LiveAstra Technologies	AstraControl - Overview	/Overview/ overview.kicad_sch	2024-08-26	A	A4	2 of 8

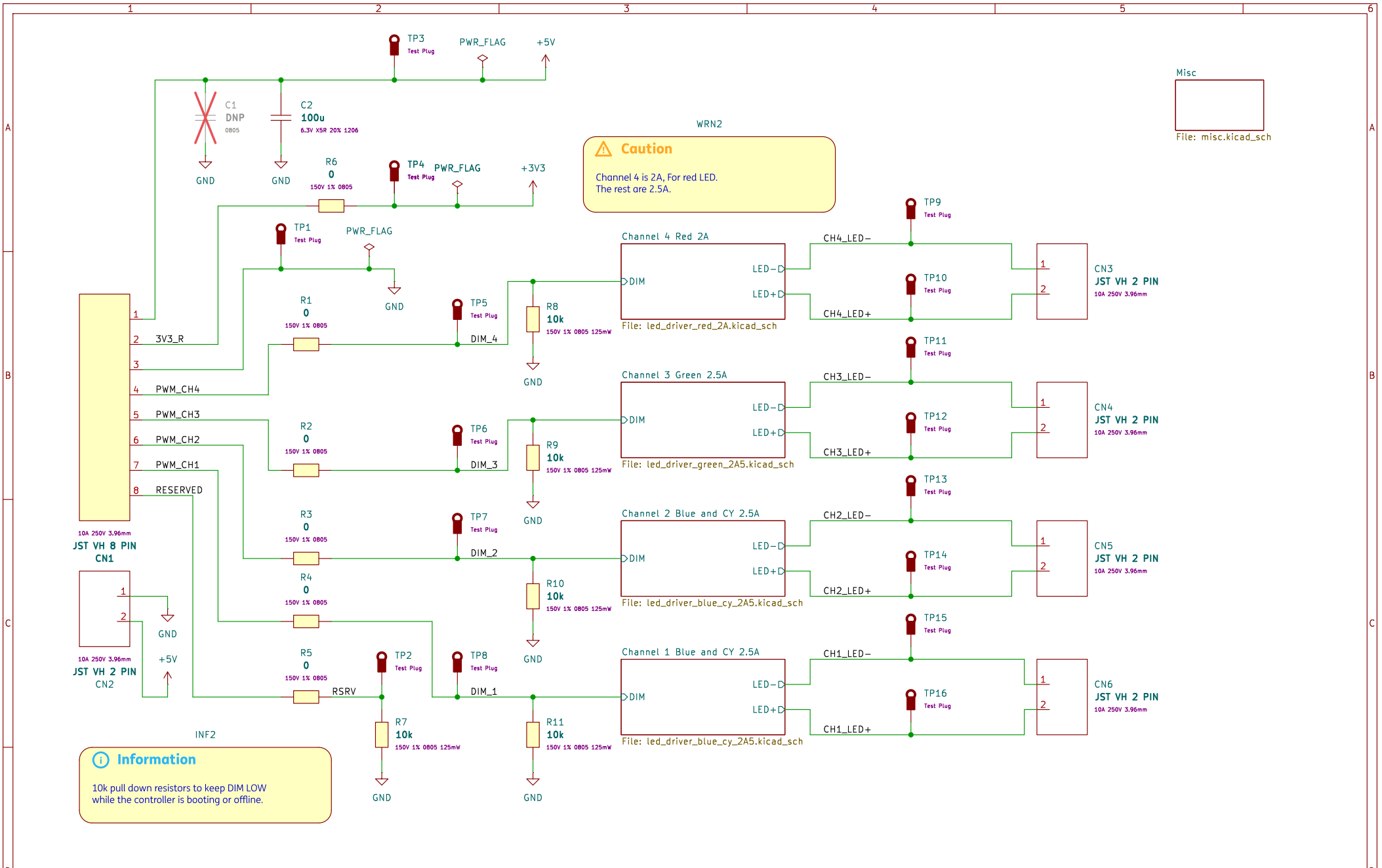

Caution
 Channel 4 is 2A, For red LED.
 The rest are 2.5A.

Misc
 File: misc.kicad_sch

Information
 10k pull down resistors to keep DIM LOW while the controller is booting or offline.

Board Name	Project Name	Company	Sheet Title	Sheet Path & File Name	Date	Revision	Size	Sheet
AstraDriver	AstraBeam	LiveAstra Technologies	AstraControl - Block Diagram	/Block Diagram/ block_diagram.kicad_sch	2024-08-26	A	A4	3 of 8

Blue and CY

Information

LED Current: 2.5A (3A Max)
 LED Current Ripple: 4%
 Inductor Current Ripple: 30%

INF3

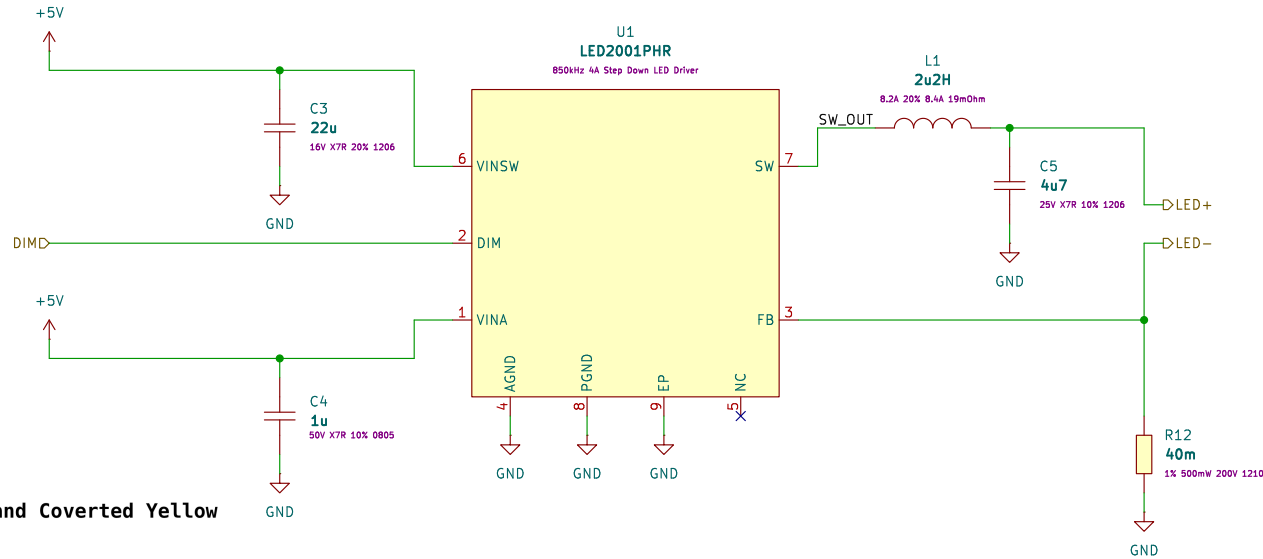

Vf: 3.25V If: 2.5A Dynamic resistance: 181 mΩ

Operating Conditions

@Vin - from 5 to 5 V: 5V
 @Iout - from 2.5 to 2.5 A: 2.5 A
 @Ta - from -55 to 150 °C: 25 °C

LED2001 For Blue and Covered Yellow

CURRENT RIPPLE DIMMING

LED Current
 LED Current Ripple: % from 1% to 20%
 Dimming Setting
 Use dimming
 Inductor Current
 IL Ripple: % from 10% to 60%

Actuals

fsw: 850 kHz
 Ton: 822.56 ns
 ILED: 2.56 A
 bandwidth: 129.04 kHz
 phase margin: 84.19°
 IC Tj: 63 °C
 ΔTj: 38 °C

Circuit - Schematic

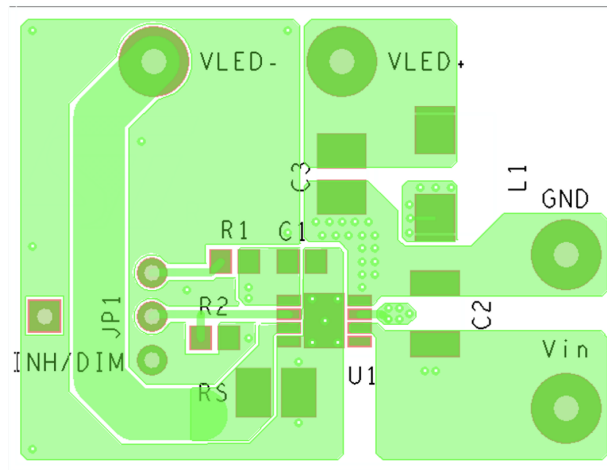
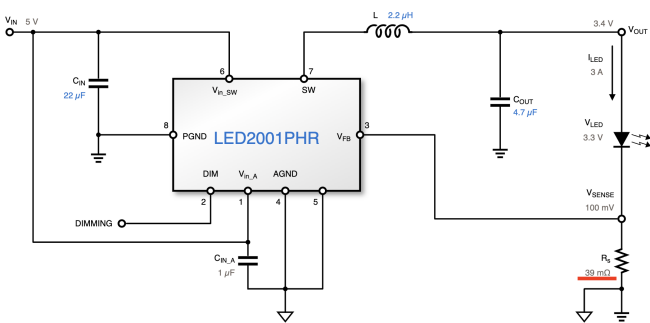

Board Name	Project Name	Company	Sheet Title	Sheet Path & File Name	Date	Revision	Size	Sheet
AstraDriver	AstraBeam	LiveAstra Technologies		/Block Diagram/Channel 1 Blue and CY 2.5A/ led_driver_blue_cy_2A5.kicad_sch	2024-08-26	A	A4	4 of 8

Blue and CY

Information

LED Current: 2.5A (3A Max)
 LED Current Ripple: 4%
 Inductor Current Ripple: 30%

INF4

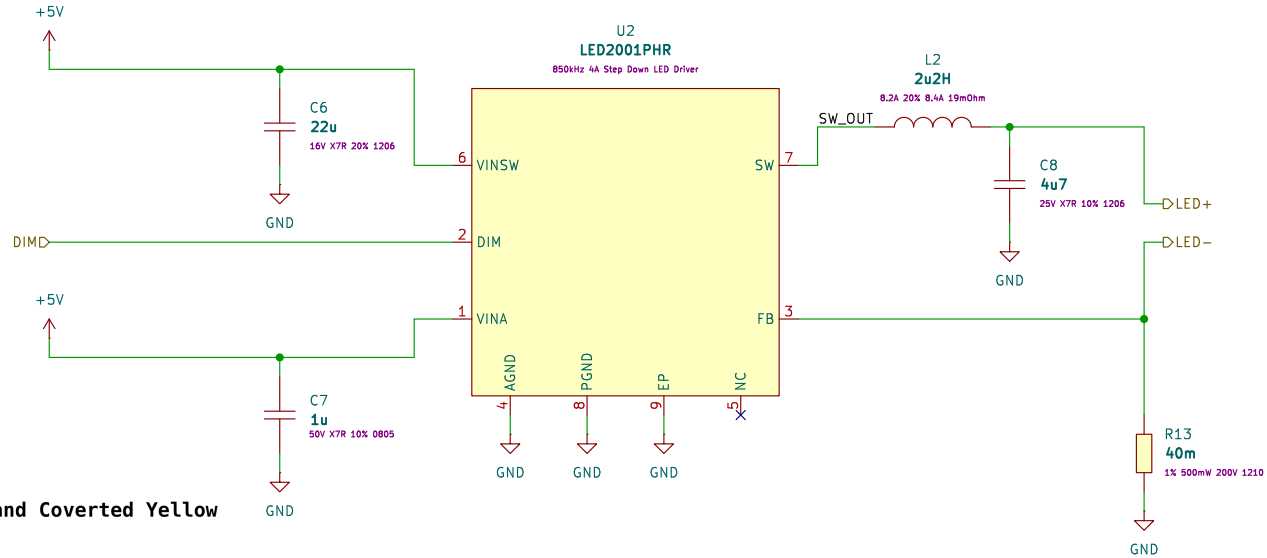

Vf: 3.25V If: 2.5A Dynamic resistance: 181 mΩ

Operating Conditions

@Vin - from 5 to 5 V: 5V

@Iout - from 2.5 to 2.5 A: 2.5A

@Ta - from -55 to 150 °C: 25 °C

LED2001 For Blue and Covered Yellow

CURRENT RIPPLE DIMMING

LED Current

LED Current Ripple: % from 1% to 20%

Dimming Setting

Use dimming

Inductor Current

IL Ripple: % from 10% to 60%

Actuals

fsw: 850 kHz

Ton: 822.56 ns

ILED: 2.56 A

bandwidth: 129.04 kHz

phase margin: 84.19°

IC Tj: 63 °C

ΔTj: 38 °C

Circuit - Schematic

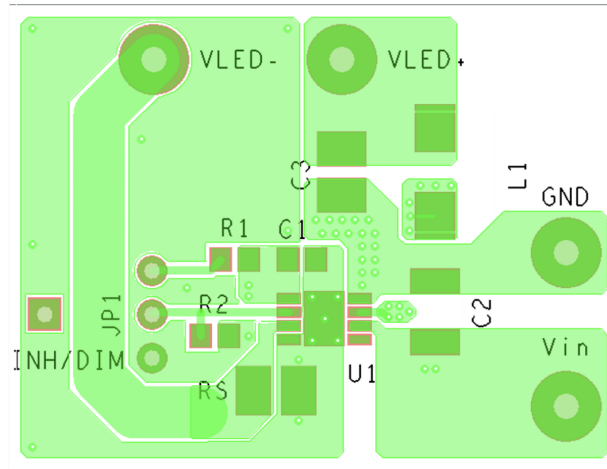
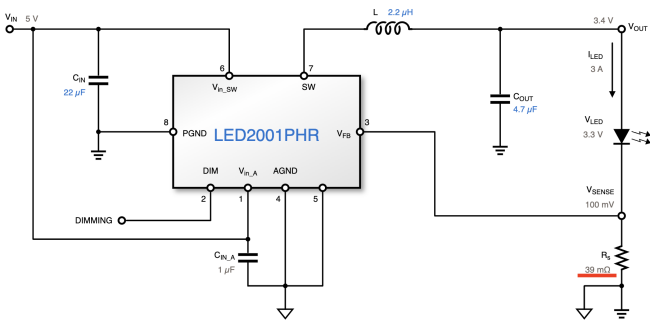

Board Name	Project Name	Company	Sheet Title	Sheet Path & File Name	Date	Revision	Size	Sheet
AstraDriver	AstraBeam	LiveAstra Technologies		/Block Diagram/Channel 2 Blue and CY 2.5A/ led_driver_blue_cy_2A5.kicad_sch	2024-08-26	A	A4	5 of 8

Green

Information

LED Current: 2.5A (3A Max)
 LED Current Ripple: 3%
 Inductor Current Ripple: 30%

INF5

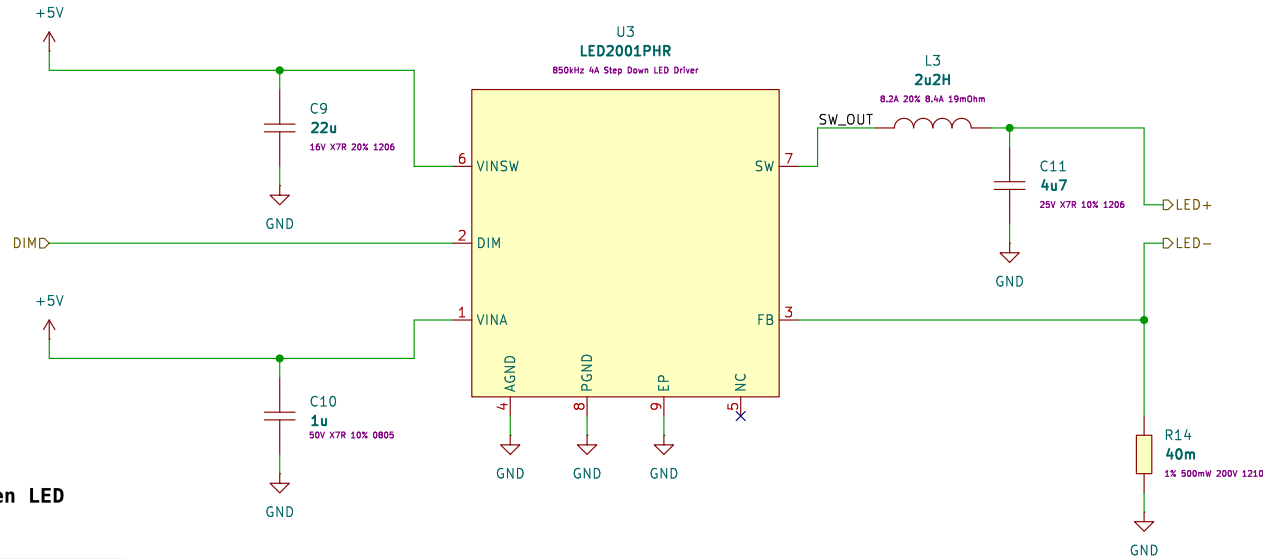

VF: 3.4V IF: 2.5A Dynamic resistance: 250 mΩ

Operating Conditions
 @Vin - from 5 to 5V: 5V
 @Iout - from 2.5 to 2.5A: 2.5A
 @Ta - from -55 to 150 °C: 25 °C

Actuals
 fsw: 850 kHz
 Ton: 857.55 ns
 ILED: 2.56A
 bandwidth: 115.09 kHz
 phase margin: 86.85°
 ICF: 62.9 °C
 ΔTj: 37.9 °C

LED2001 For Green LED

CURRENT RIPPLE DIMMING

LED Current

LED Current Ripple: % from 1% to 20%

Dimming Setting

Use dimming

Inductor Current

IL Ripple: % from 10% to 60%

Circuit - Schematic

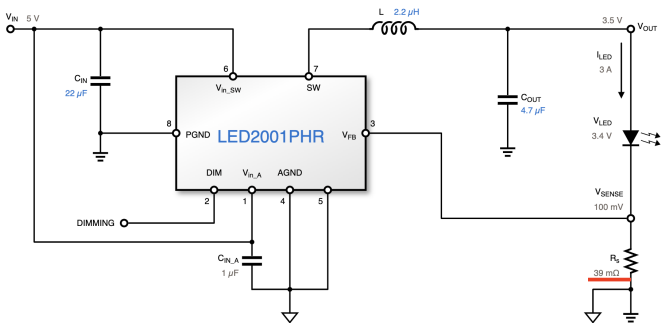

Board Name	Project Name	Company	Sheet Title	Sheet Path & File Name	Date	Revision	Size	Sheet
AstraDriver	AstraBeam	LiveAstra Technologies		/Block Diagram/Channel 3 Green 2.5A/ led_driver_green_2A5.kicad_sch	2024-08-26	A	A4	6 of 8

Red

Information

LED Current: 2.13A (2.5A Max)
LED Current Ripple: 4%
Inductor Current Ripple: 34%

INF6

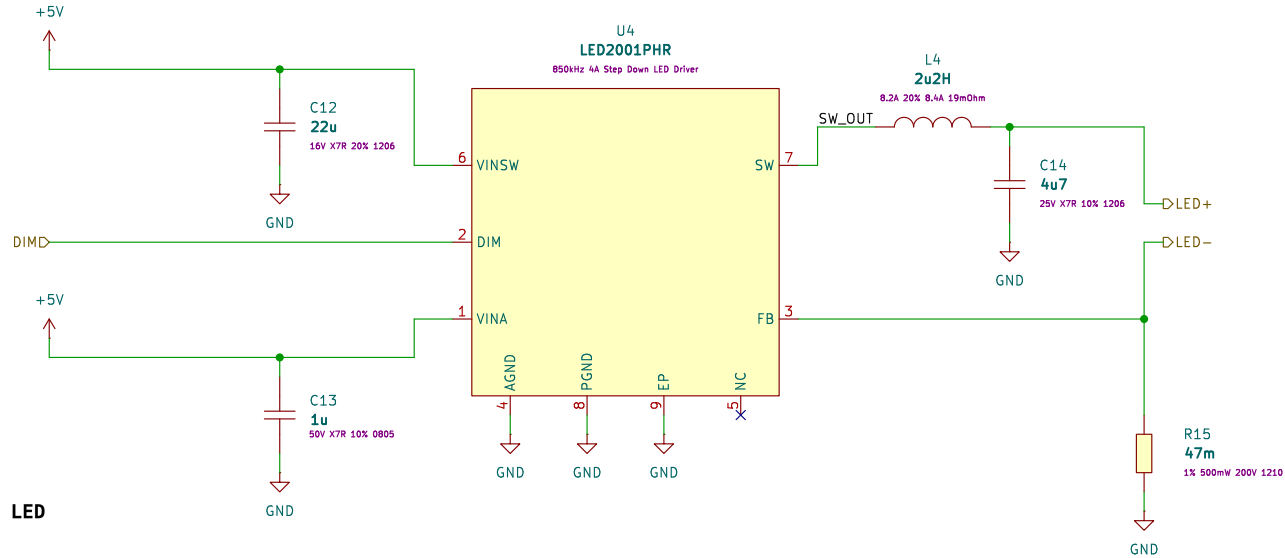

VF: 2.55V, IR: 2.1A, Dynamic resistance: 285 mΩ

Operating Conditions

@Vin - from 5 to 5V: 5V
@Iout - from 2.1 to 2.1A: 2.1A
@Ta - from -55 to 150°C: 25°C

Actuals

fsw: 850 kHz
Ton: 651.75 ns
ILed: 2.13 A
bandwidth: 117.54 kHz
phase margin: 77.58°
IC TJ: 53.8°C
ΔTj: 28.8°C

LED2001 For Red LED

CURRENT RIPPLE DIMMING

LED Current

LED Current Ripple: % from 1% to 20%

Dimming Setting

Use dimming

Inductor Current

IL Ripple: % from 10% to 60%

Circuit - Schematic

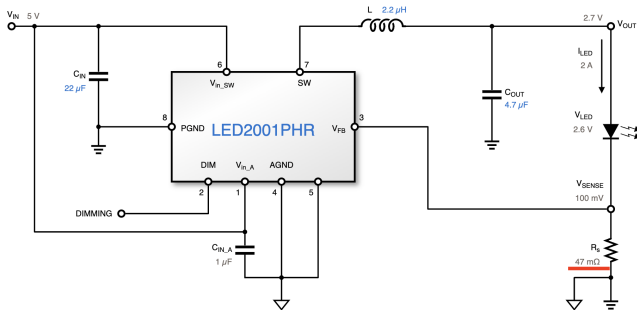

Board Name	Project Name	Company	Sheet Title	Sheet Path & File Name	Date	Revision	Size	Sheet
AstraDriver	AstraBeam	LiveAstra Technologies		/Block Diagram/Channel 4 Red 2A/ led_driver_red_2A.kicad_sch	2024-08-26	A	A4	7 of 8

Misc

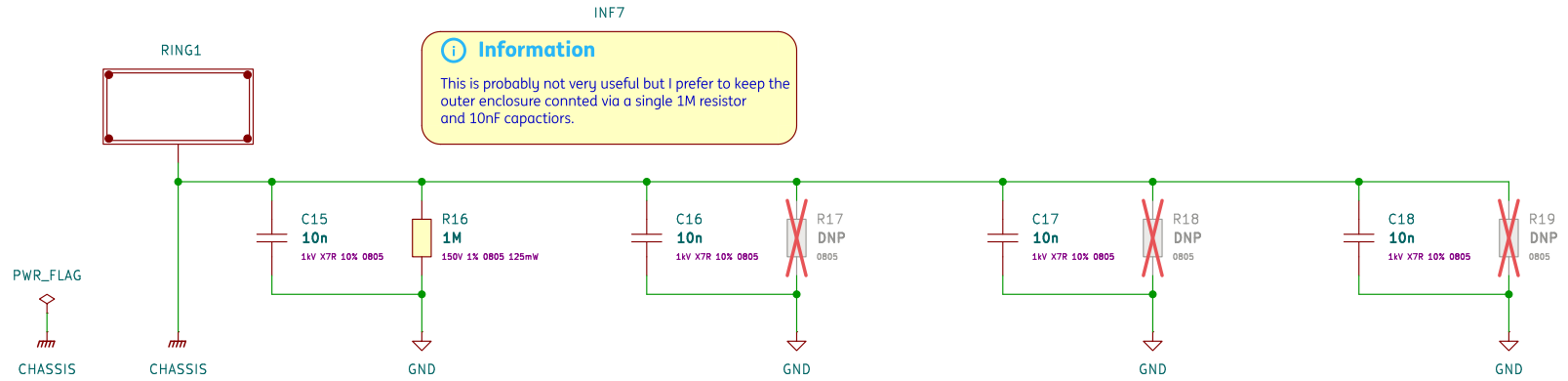

Board Name	Project Name	Company	Sheet Title	Sheet Path & File Name	Date	Revision	Size	Sheet
AstraDriver	AstraBeam	LiveAstra Technologies	AstraControl - Block Diagram	/Block Diagram/Misc/ misc.kicad_sch	2024-08-26	A	A4	8 of 8