

# AstraControl

In review

ESP32-based control PCB uses WiFi with an external antenna and 5Mbps RS-485 for communication, supporting various sensors and HMI devices for high-power LED fixtures or strips. One device can act as master or all fixtures will receive data from a dedicated receiver.

## Features

- Up to 5V 10A Input
- USB C
- External WiFi Antenna
- 5Mbps RS485 (half-duplex)
- ESP32-S3 SoC integrating Wi-Fi 4 and Bluetooth 5 (LE)
- 2x I2C Auxilary (Qwiic connector)
- 4 Channel LED PWM
- 4x 5V GPIO
- 4 Wire 5V Fan
- 5V to 3.3V Step Down DC-DC
- UART
- I2S (Qwiic connector)
- External button and status LED

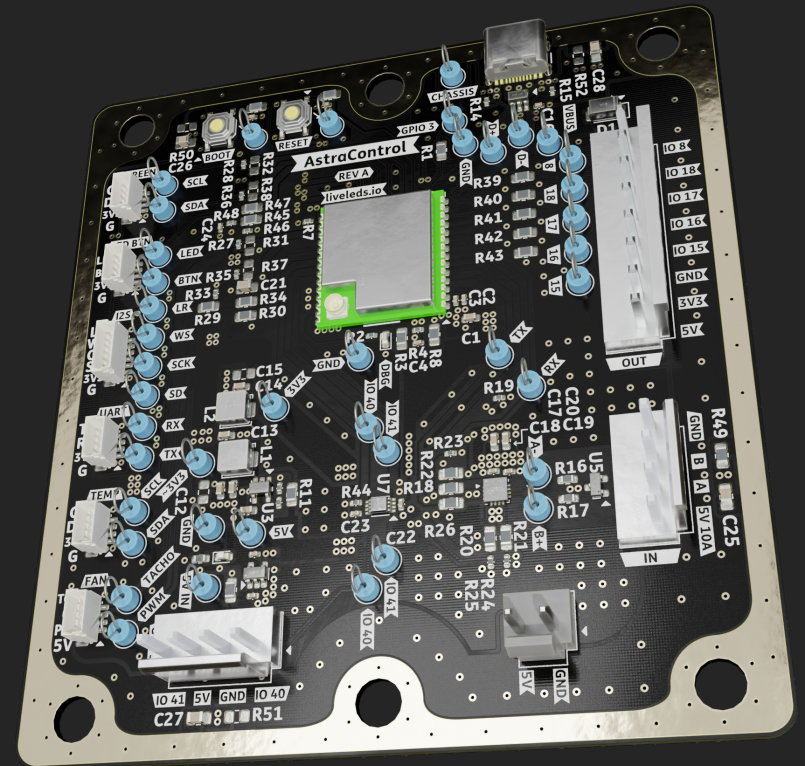

Render for reference only

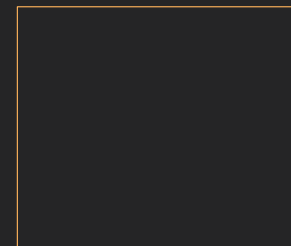

File: overview.kicad\_sch

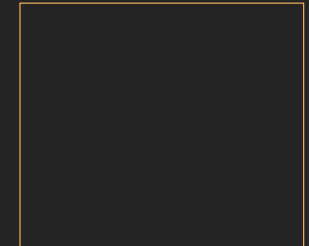

File: block\_diagram.kicad\_sch

Board Name	Project Name	Company	Sheet Title	Sheet Path & File Name	Date	Revision	Size	Sheet
AstraControl	AstraBeam	LiveAstra Technologies	AstraControl - Schematic	/ AstraControl.kicad_sch	2024-08-26	B	A4	1 of 16

# Overview

22 April 2024

Page	Description	Page	Description
1	Cover	9	USB-C
2	Overview	10	UART to RS-485
3	Block Diagram	11	Fan, Temperature, Screen
4	MCU	12	PWM Connector
5	MCU Enable and Boot	13	3.3V To 5V Logic Shifter
6	5V Protection	14	5V GPIO Connector
7	5V to 3.3V	15	Button, Status LED, UART, I2S
8	Power Connectors	16	Misc

## Notes

- Second time creating a PCB. Mistakes were probably made.
- Some features are not necessary but used for learning and experimentation.
- PCB components are spread apart a bit more than the minimum allowed clearance for easy debugging and adjustments.
- Some aspects of the schematic / PCB are more verbose to aid in the review process.

QST1

### Question

Something is unclear or a missing piece of information potentially needs to be explored further.

INF1

### Information

Generic information box to inform about specifics of the part or layout, notes, helpful information.

CRT1

### Critical

It is critical to follow the instructions here. Failure to do so will result in poor performance or failure.

WRN1

### Caution

Extra care is required here. Pay attention to details, routing, and try your best to follow the advice.

Board Name	Project Name	Company	Sheet Title	Sheet Path & File Name	Date	Revision	Size	Sheet
AstraControl	AstraBeam	LiveAstra Technologies	AstraControl - Root	/Overview/ overview.kicad_sch	2024-08-26	B	A4	2 of 16

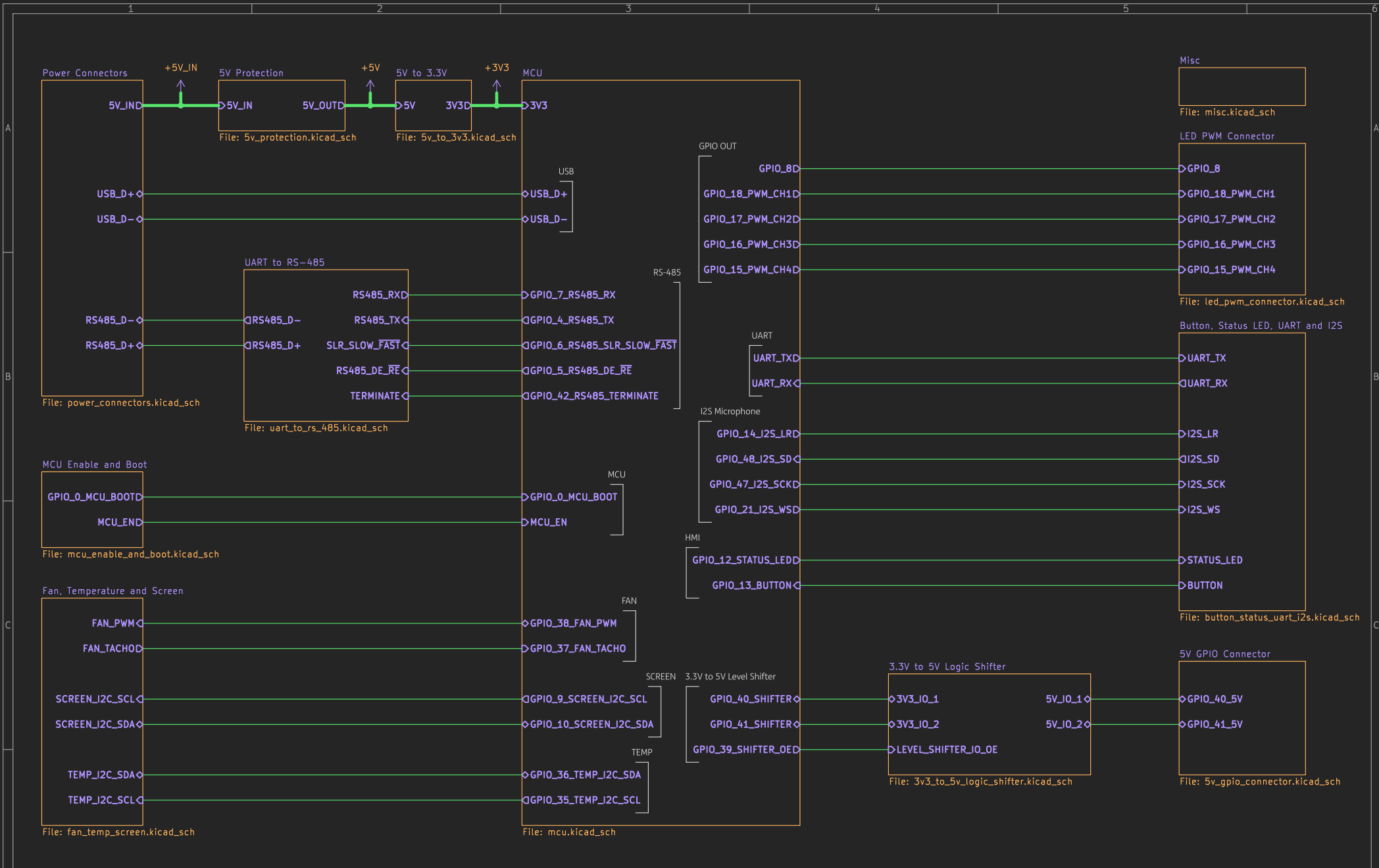

Board Name	Project Name	Company	Sheet Title	Sheet Path & File Name	Date	Revision	Size	Sheet
AstraControl	AstraBeam	LiveAstra Technologies	AstraControl - Root	/Block Diagram/ block_diagram.kicad_sch	2024-08-26	B	A4	3 of 16

# MCU

U1  
ESP32-S3-WROOM-1U-N8  
External Antenna, 8MB Flash  
C2980297

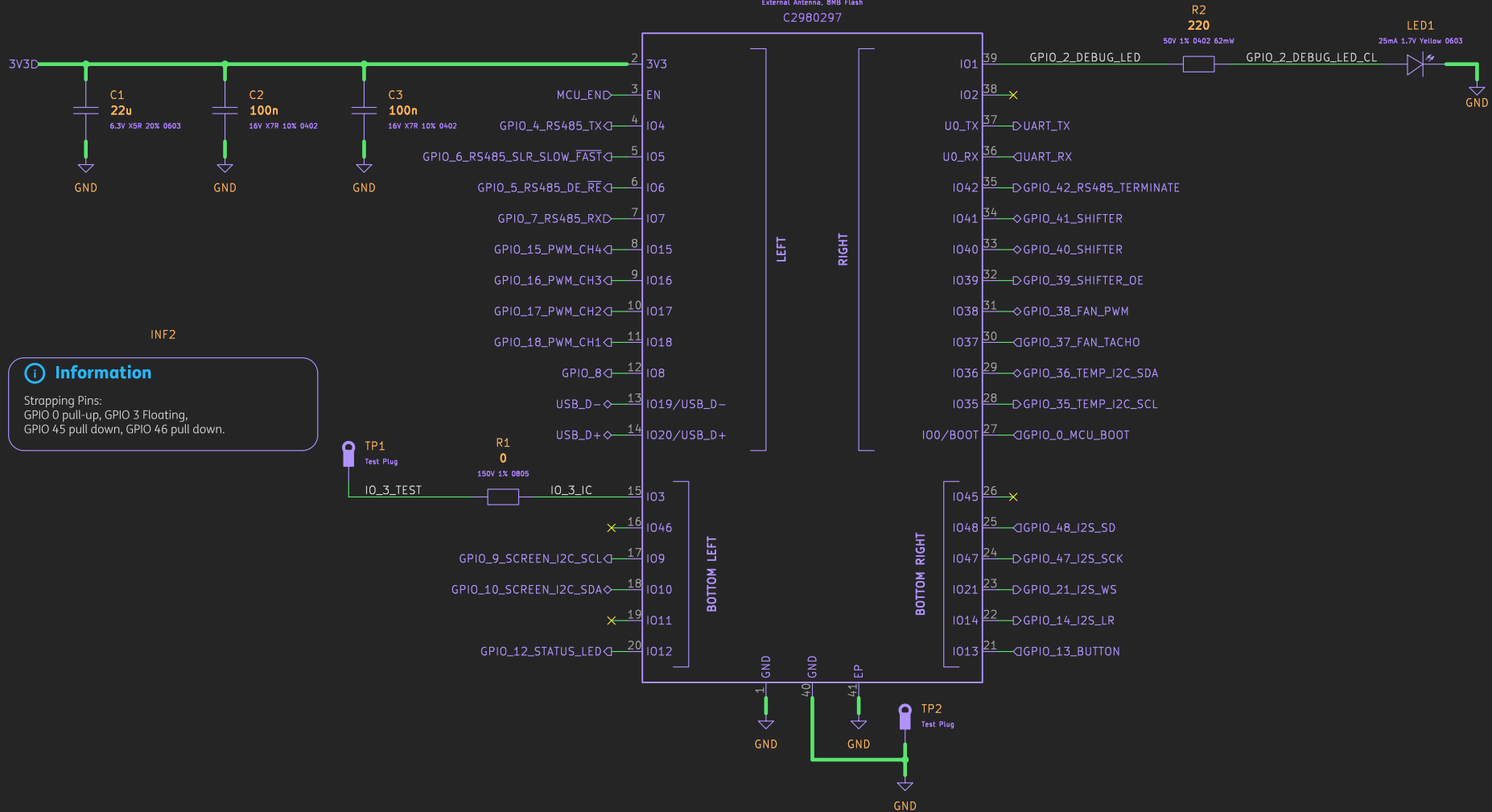

## Information

Strapping Pins:  
GPIO 0 pull-up, GPIO 3 Floating,  
GPIO 45 pull down, GPIO 46 pull down.

Board Name	Project Name	Company	Sheet Title	Sheet Path & File Name	Date	Revision	Size	Sheet
AstraControl	AstraBeam	LiveAstra Technologies	AstraControl - Root	/Block Diagram/MCU/ mcu.kicad_sch	2024-08-26	B	A4	4 of 16

# MCU Enable & Boot

INF3

## Information

To ensure that the power supply to the ESP32-S3 chip is stable during power-up, it is advised to add an RC delay circuit at the EN pin.

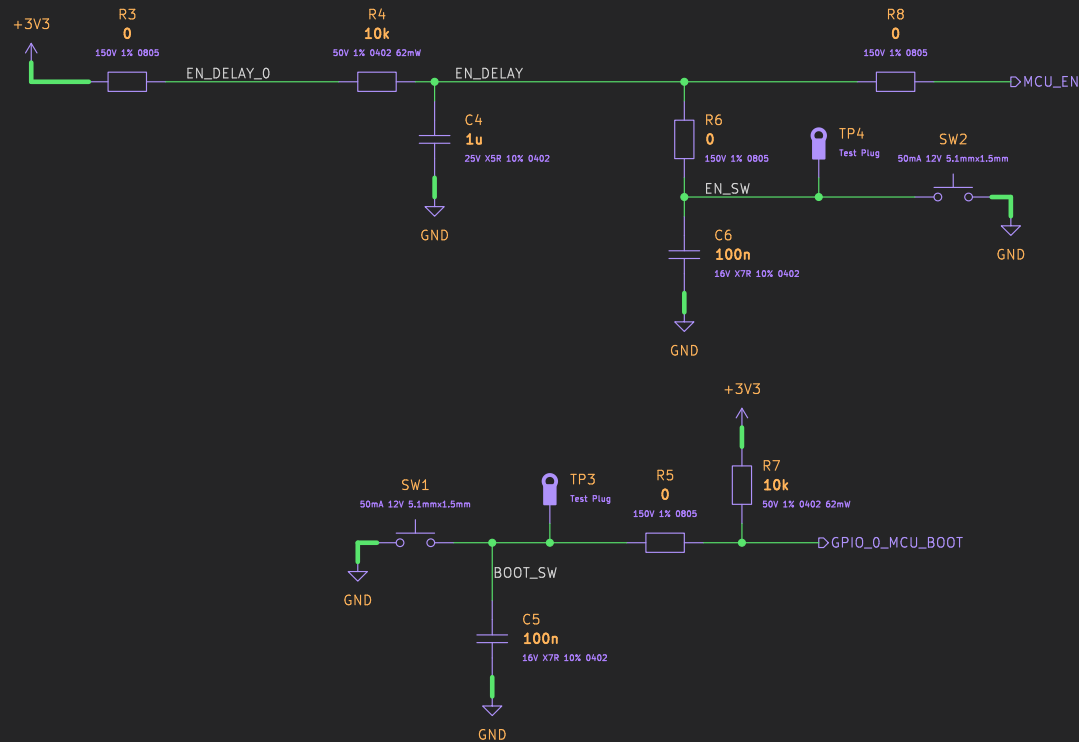

Board Name	Project Name	Company	Sheet Title	Sheet Path & File Name	Date	Revision	Size	Sheet
AstraControl	AstraBeam	LiveAstra Technologies	AstraControl - Root	/Block Diagram/MCU Enable and Boot/ mcu_enable_and_boot.kicad_sch	2024-08-26	B	A4	5 of 16

# 5V Protection

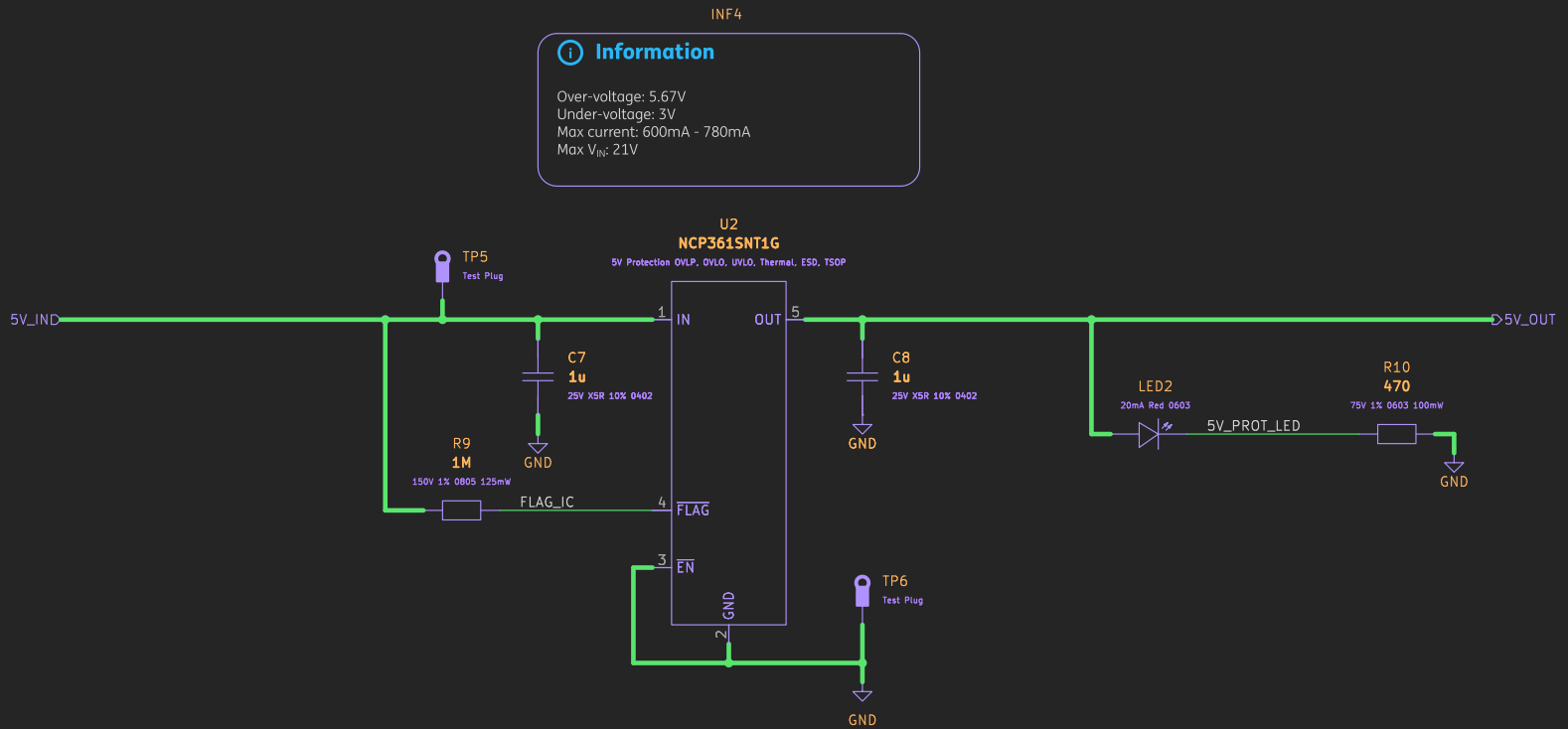

## Information

Over-voltage: 5.67V  
 Under-voltage: 3V  
 Max current: 600mA - 780mA  
 Max  $V_{IN}$ : 21V

Board Name	Project Name	Company	Sheet Title	Sheet Path & File Name	Date	Revision	Size	Sheet
AstraControl	AstraBeam	LiveAstra Technologies	AstraControl - Root	/Block Diagram/5V Protection/ 5v_protection.kicad_sch	2024-08-26	B	A4	6 of 16

# 5V to 3.3V

INF5

### Information

$$V_O = V_{FB} * [1 + R1 / R2]$$

$$V_O = 0.6V * (1 + 10k/45.3k) = 3.318V$$

INF6

### Information

PI Filter:  
Cutoff frequency: -3dB at 40KHz  
Mostly for educational purposes.

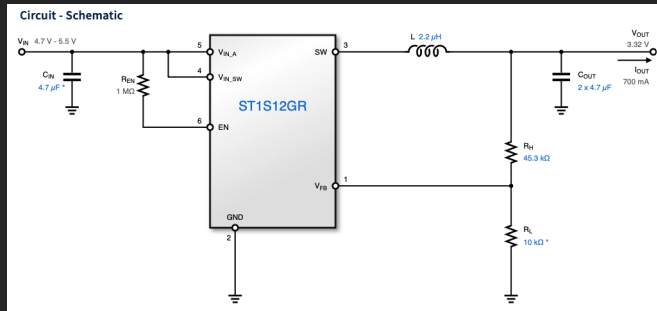
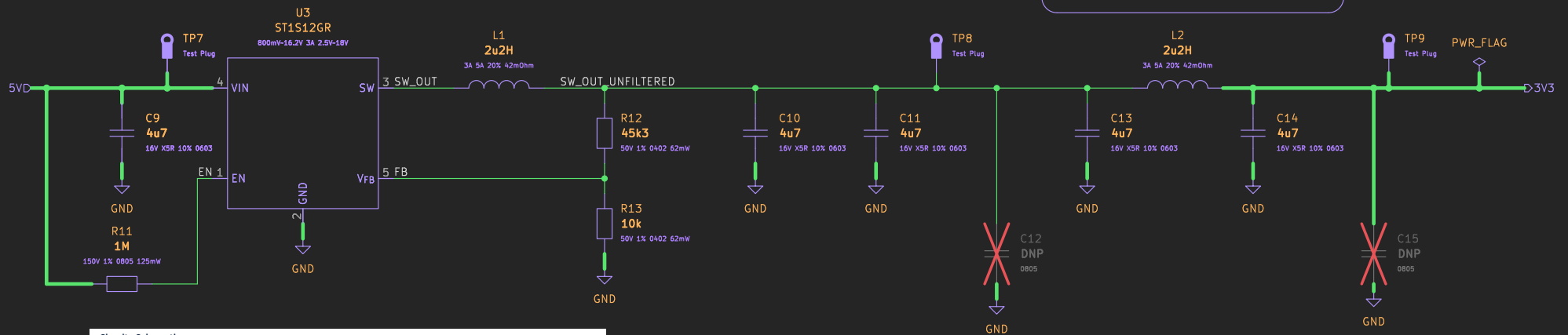

Board Name	Project Name	Company	Sheet Title	Sheet Path & File Name	Date	Revision	Size	Sheet
AstraControl	AstraBeam	LiveAstra Technologies	AstraControl - Root	/Block Diagram/5V to 3.3V/ 5v_to_3v3.kicad_sch	2024-08-26	B	A4	7 of 16

# Power connectors

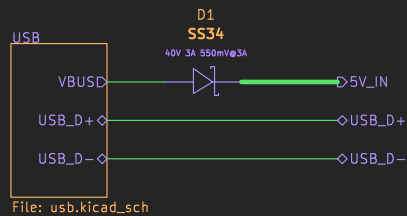
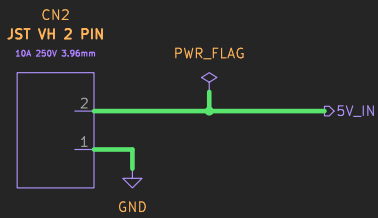
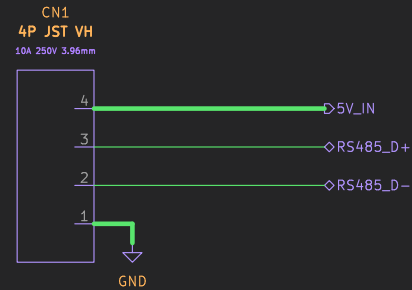

Board Name	Project Name	Company	Sheet Title	Sheet Path & File Name	Date	Revision	Size	Sheet
AstraControl	AstraBeam	LiveAstra Technologies	AstraControl - Root	/Block Diagram/Power Connectors/ power_connectors.kicad_sch	2024-08-26	B	A4	8 of 16



# USB C

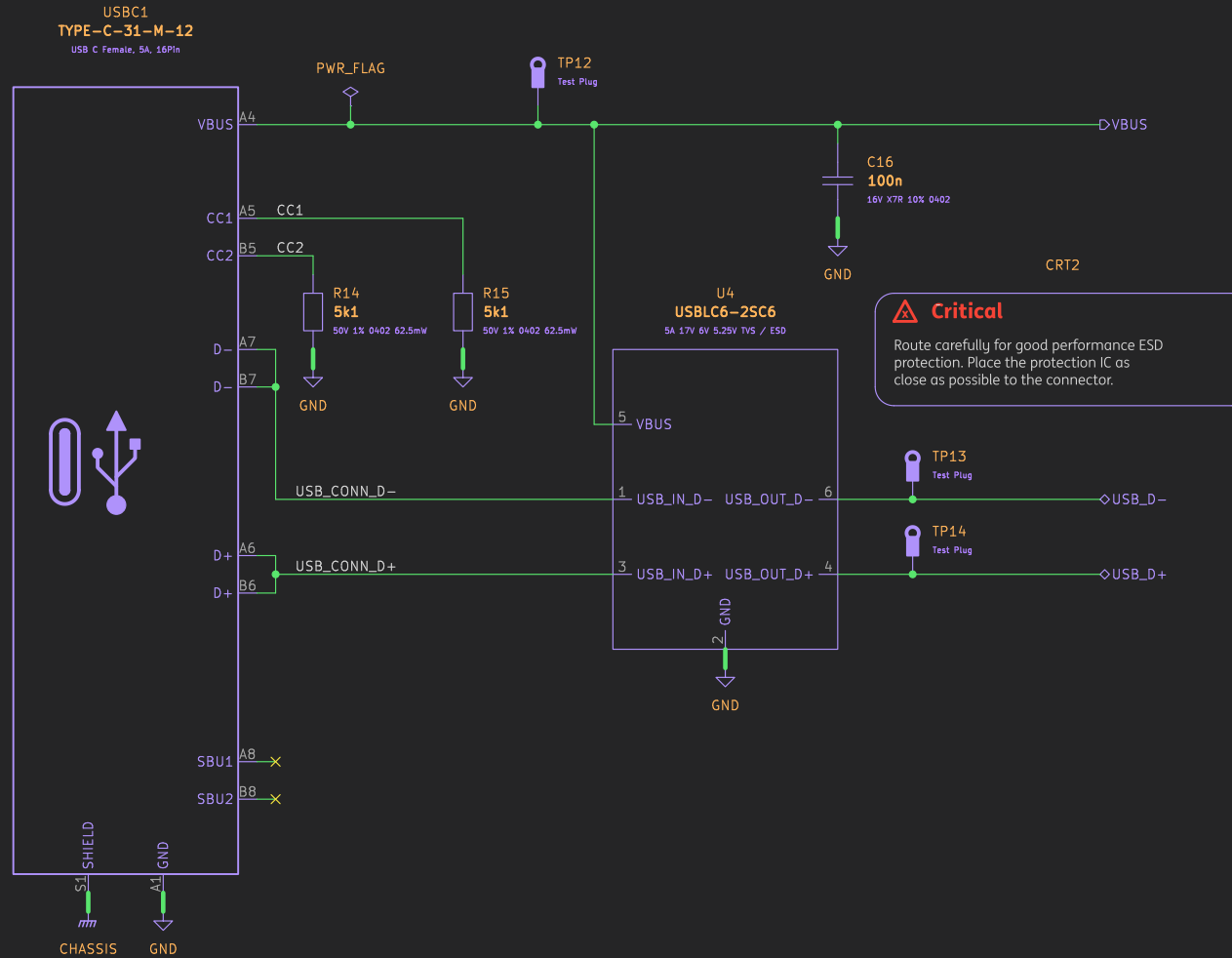

Board Name	Project Name	Company	Sheet Title	Sheet Path & File Name	Date	Revision	Size	Sheet
AstraControl	AstraBeam	LiveAstra Technologies	AstraControl - Root	/Block Diagram/Power Connectors/USB/ usb.kicad_sch	2024-08-26	B	A4	9 of 16

# UART to RS-485

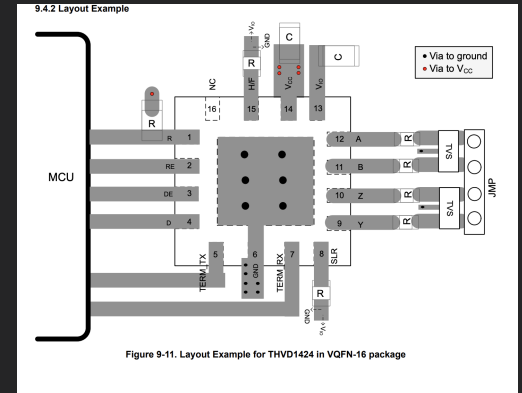
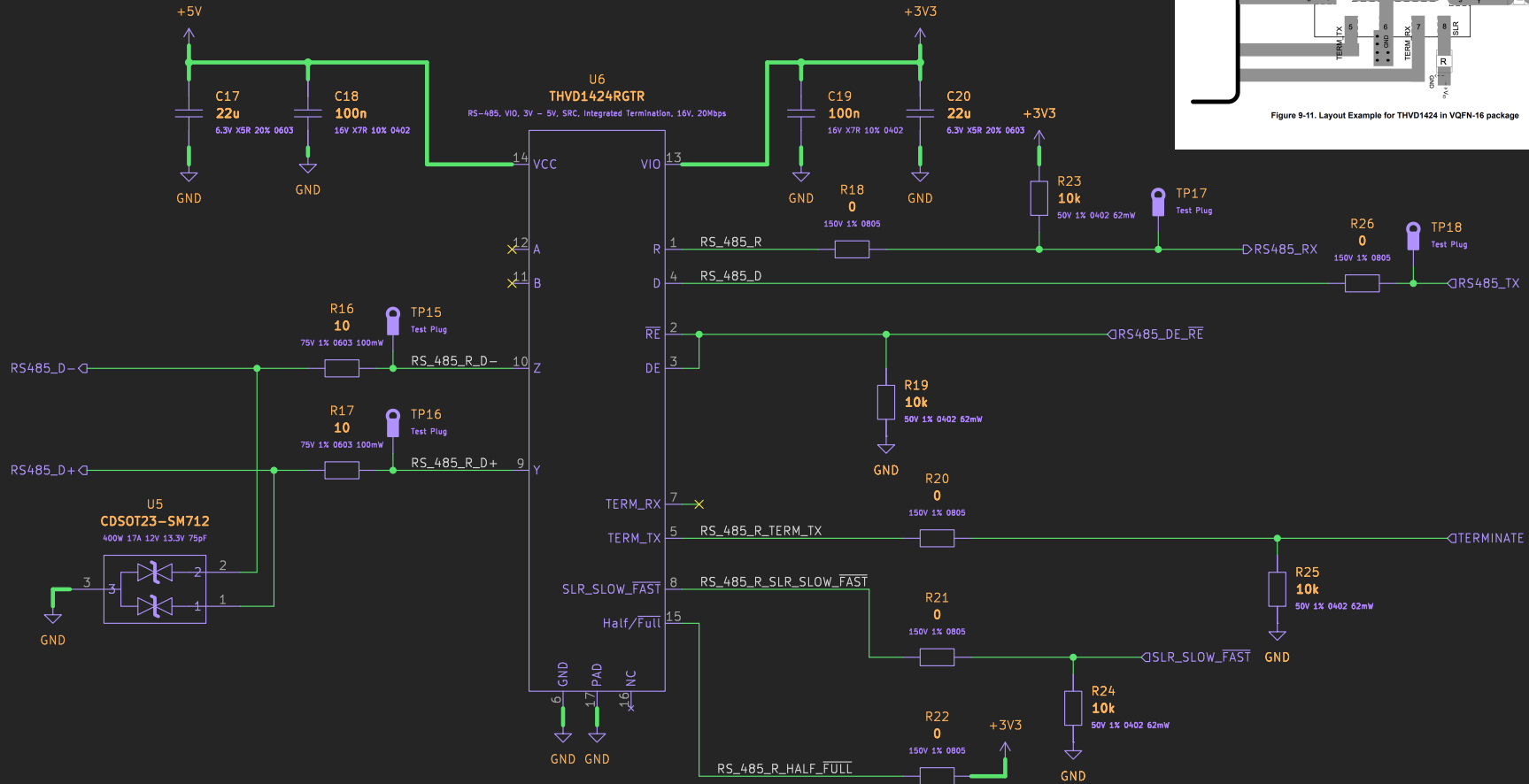

Board Name	Project Name	Company	Sheet Title	Sheet Path & File Name	Date	Revision	Size	Sheet
AstraControl	AstraBeam	LiveAstra Technologies	AstraControl - Root	/Block Diagram/UART to RS-485/ uart_to_rs_485.kicad_sch	2024-08-26	B	A4	10 of 16

# Fan Temperature Screen

INF7

**Information**

RC Filter  
Cutoff: 482KHz

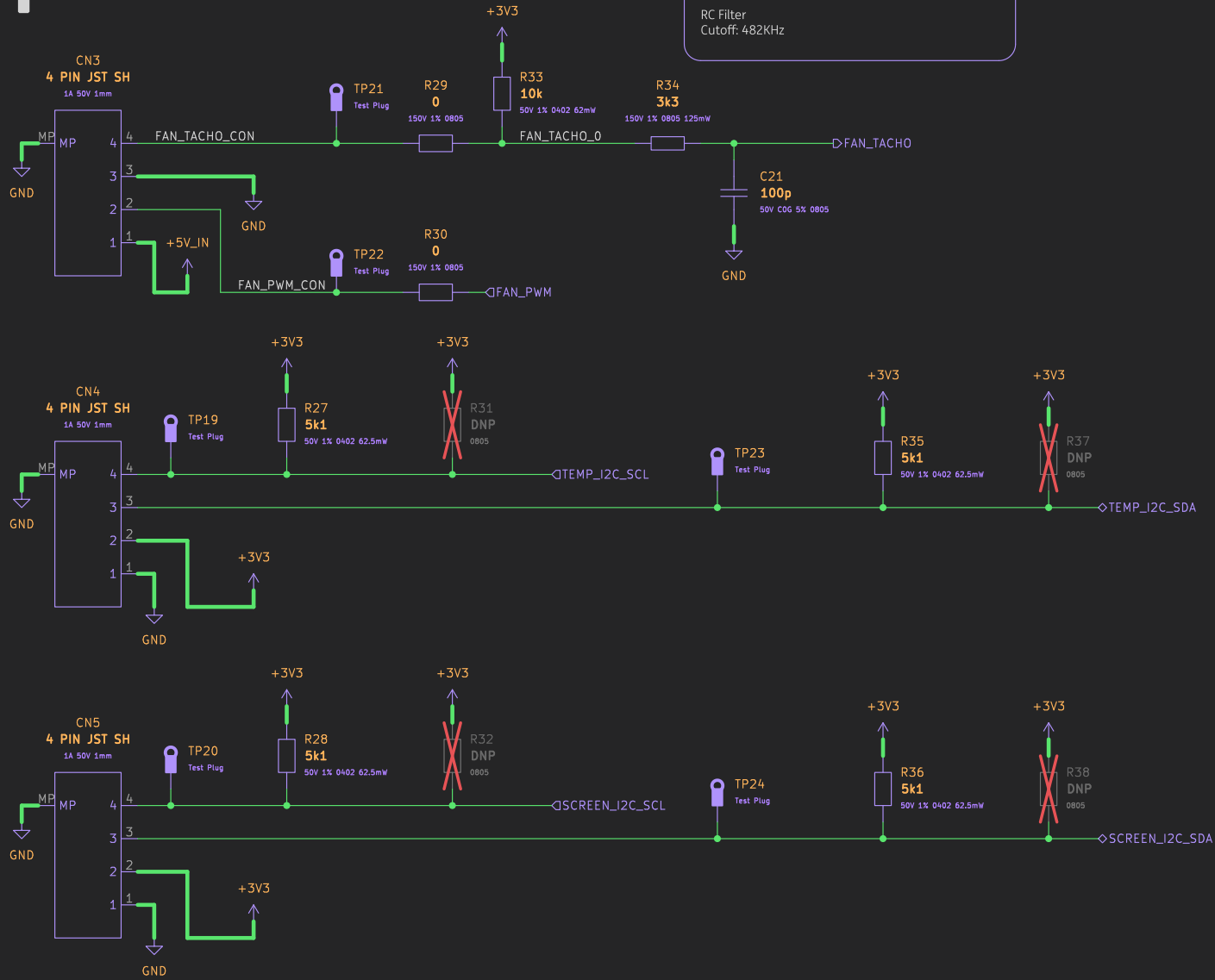

Board Name	Project Name	Company	Sheet Title	Sheet Path & File Name	Date	Revision	Size	Sheet
AstraControl	AstraBeam	LiveAstra Technologies	AstraControl - Root	/Block Diagram/Fan, Temperature and Screen/ fan_temp_screen.kicad_sch	2024-08-26	B	A4	11 of 16

# PWM Connector

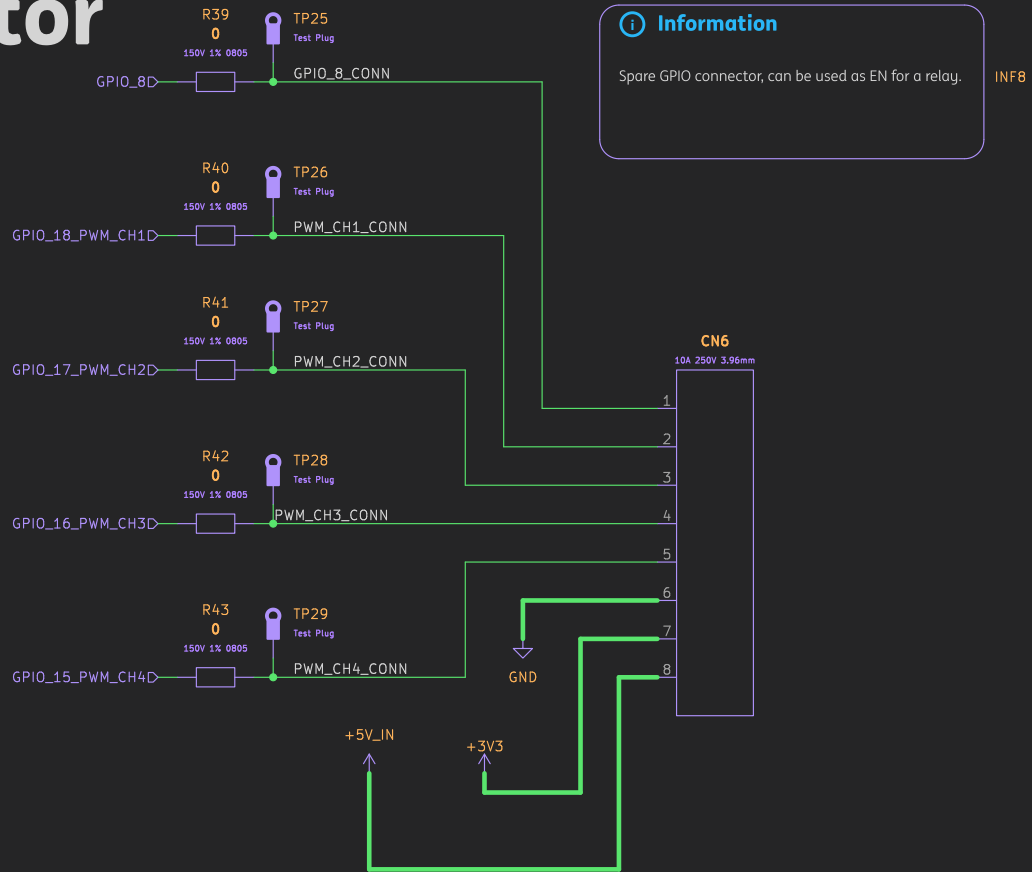

**Information**  
Spare GPIO connector, can be used as EN for a relay. INF8

Board Name	Project Name	Company	Sheet Title	Sheet Path & File Name	Date	Revision	Size	Sheet
AstraControl	AstraBeam	LiveAstra Technologies	AstraControl - Root	/Block Diagram/LED PWM Connector/ led_pwm_connector.kicad_sch	2024-08-26	B	A4	12 of 16

# 3V3 to 5V Logic Shifter

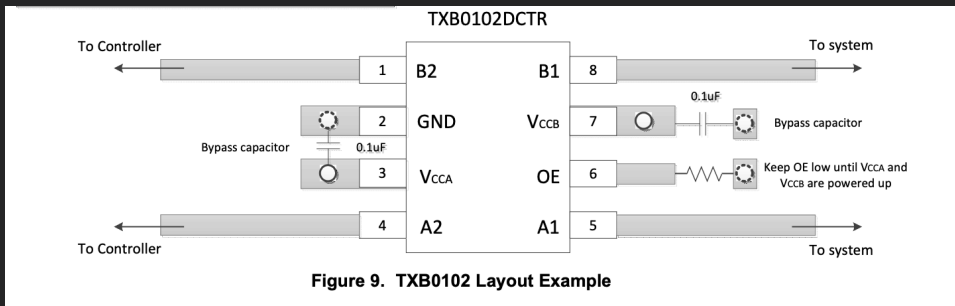
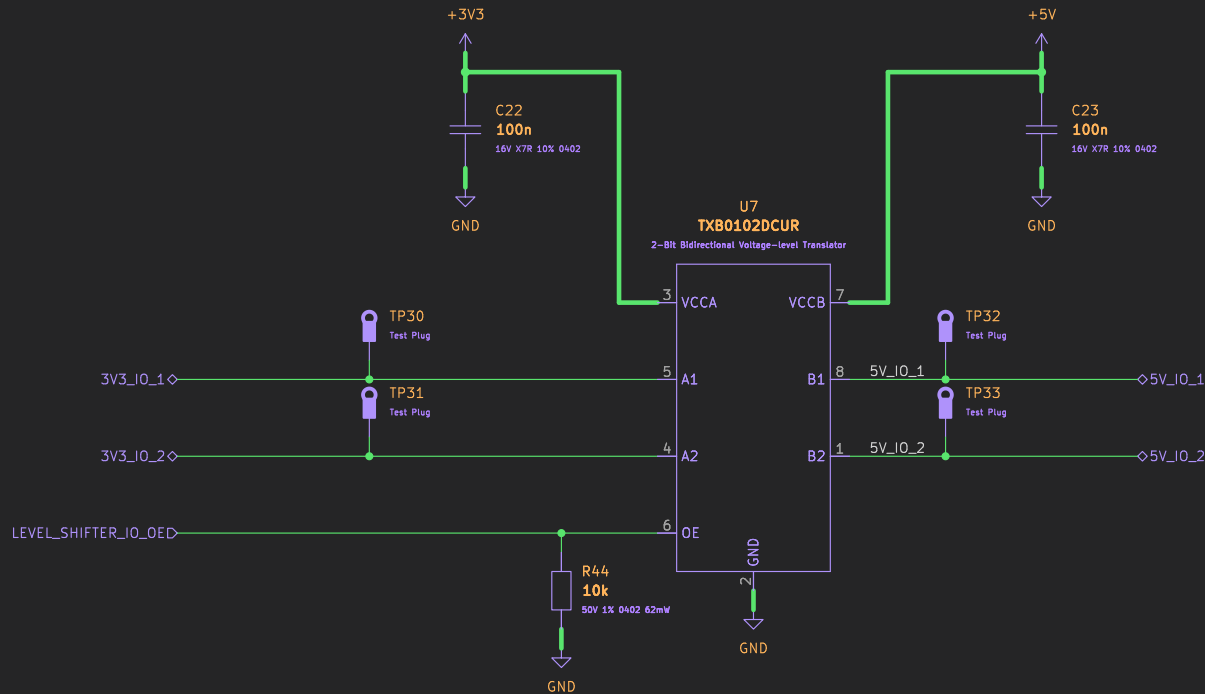

PIN		TYPE <sup>(1)</sup>	DESCRIPTION
NAME	NO.		
B2	1	I/O	Input/output B2. Referenced to V <sub>CCB</sub>
GND	2	S	Ground
V <sub>CCA</sub>	3	S	A-port supply voltage. $1.1\text{ V} \leq V_{CCA} \leq 3.6\text{ V}$ , $V_{CCA} \leq V_{CCB}$
A2	4	I/O	Input/output A2. Referenced to V <sub>CCA</sub>
A1	5	I/O	Input/output A1. Referenced to V <sub>CCA</sub>
OE	6	I	3-state output-mode enable. Pull OE low to place all outputs in 3-state mode. Referenced to V <sub>CCA</sub>
V <sub>CCB</sub>	7	S	B-port supply voltage. $1.65\text{ V} \leq V_{CCB} \leq 5.5\text{ V}$
B1	8	I/O	Input/output B1. Referenced to V <sub>CCB</sub>

Board Name	Project Name	Company	Sheet Title	Sheet Path & File Name	Date	Revision	Size	Sheet
AstraControl	AstraBeam	LiveAstra Technologies	AstraControl - Root	/Block Diagram/3.3V to 5V Logic Shifter/ 3v3_to_5v_logic_shifter.kicad_sch	2024-08-26	B	A4	13 of 16

# 5V GPIO Connector

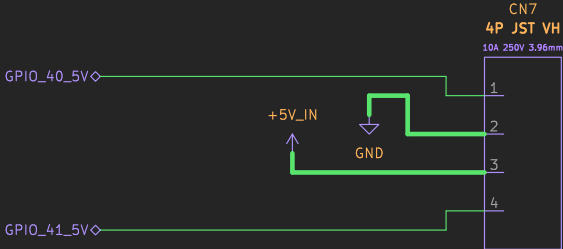

Board Name	Project Name	Company	Sheet Title	Sheet Path & File Name	Date	Revision	Size	Sheet
AstraControl	AstraBeam	LiveAstra Technologies	AstraControl - Root	/Block Diagram/5V GPIO Connector/ 5v_gpio_connector.kicad_sch	2024-08-26	B	A4	14 of 16

# HMI UART I2S

INF9

## Information

ESP32-S3 WROOM has a 4990mΩ resistor on the TX line.

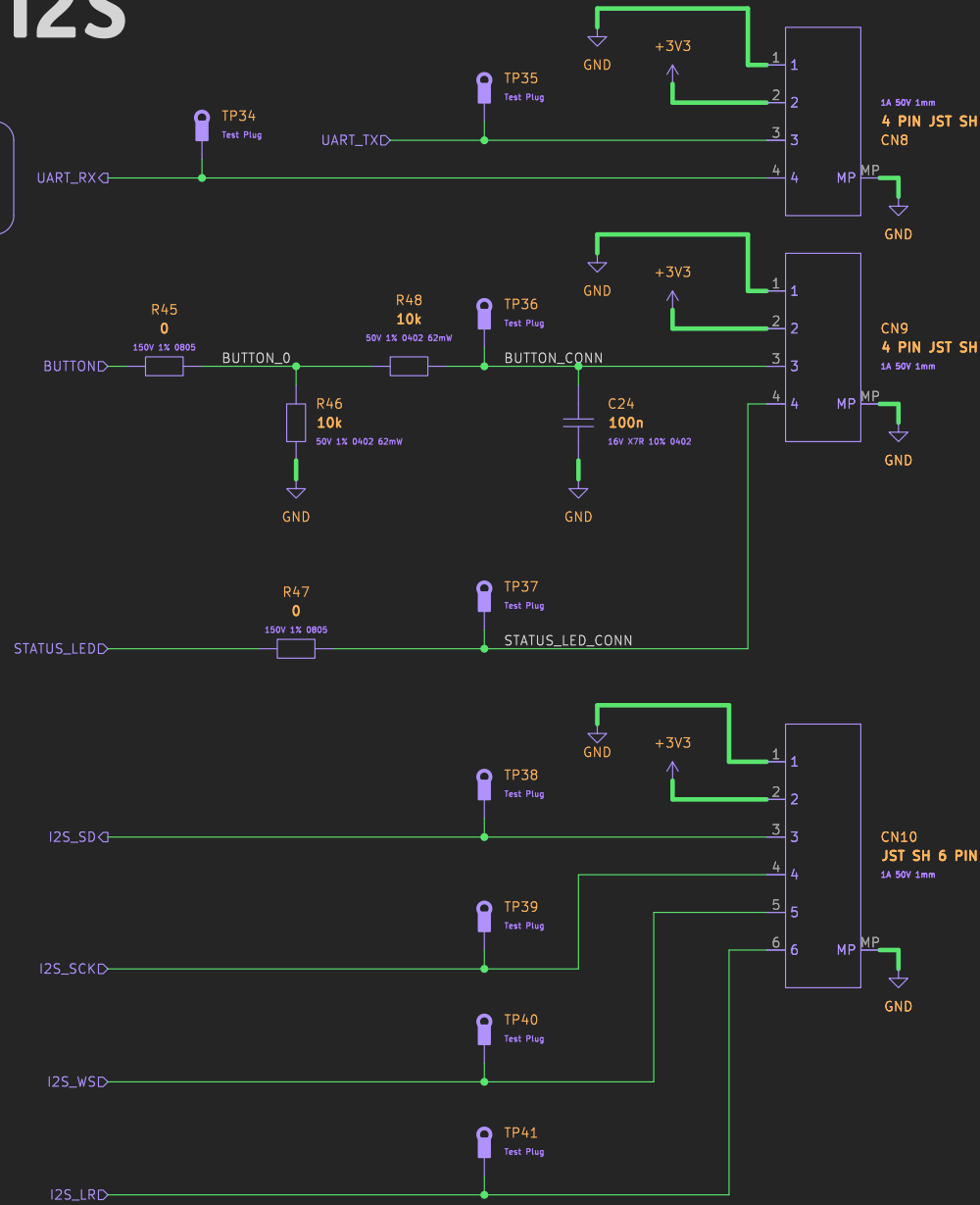

Board Name	Project Name	Company	Sheet Title	Sheet Path & File Name	Date	Revision	Size	Sheet
AstraControl	AstraBeam	LiveAstra Technologies	AstraControl - Root	/Block Diagram/Button, Status LED, UART and I2S/ button_status_uart_i2s.kicad_sch	2024-08-26	B	A4	15 of 16

# Misc

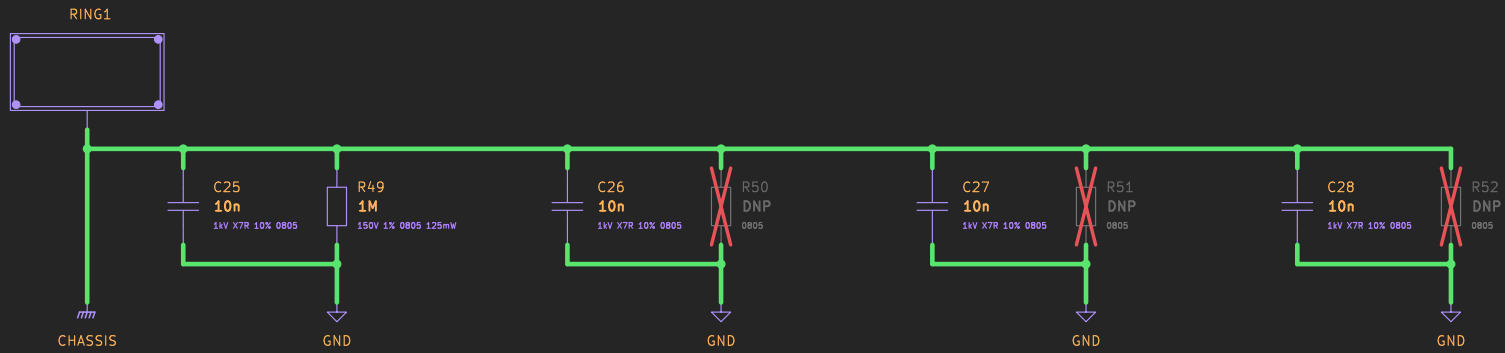

Board Name	Project Name	Company	Sheet Title	Sheet Path & File Name	Date	Revision	Size	Sheet
AstraControl	AstraBeam	LiveAstra Technologies	AstraControl - Root	/Block Diagram/Misc/ misc.kicad_sch	2024-08-26	B	A4	16 of 16